ERV (Energy Recovery Ventilator)

MODELS**(Ceiling mounted duct type)****VAM300GVJU****VAM470GVJU****VAM600GVJU****VAM1200GVJU**

English

Français

Español

Read these instructions carefully before installation.
Keep this manual in a handy place for future reference.
This manual should be left with the equipment owner.

Lire soigneusement ces instructions avant l'installation.
Conserver ce manuel à portée de main pour référence ultérieure.
Ce manuel doit être donné au propriétaire de l'équipement.

Lea cuidadosamente estas instrucciones antes de instalar.
Guarde este manual en un lugar a mano para leer en caso de tener alguna duda.
Este manual debe permanecer con el propietario del equipo.

• VAM300GVJU, VAM470GVJU, VAM600GVJU

• VAM1200GVJU

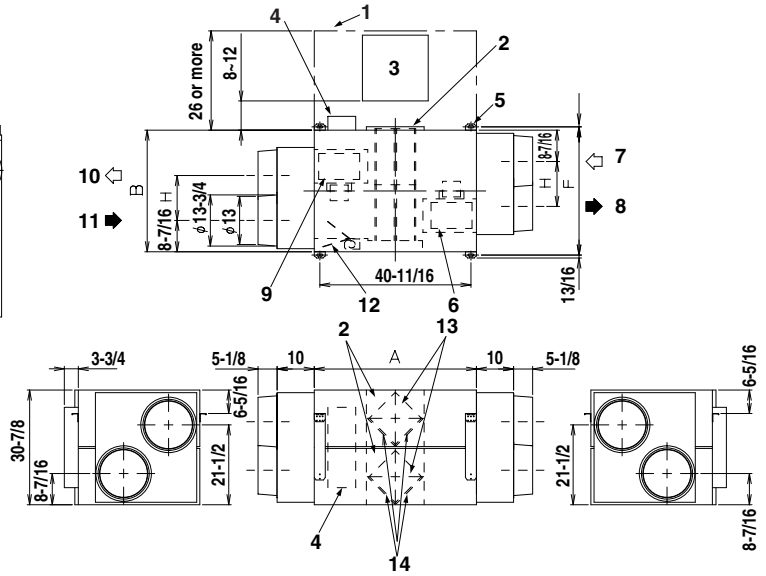
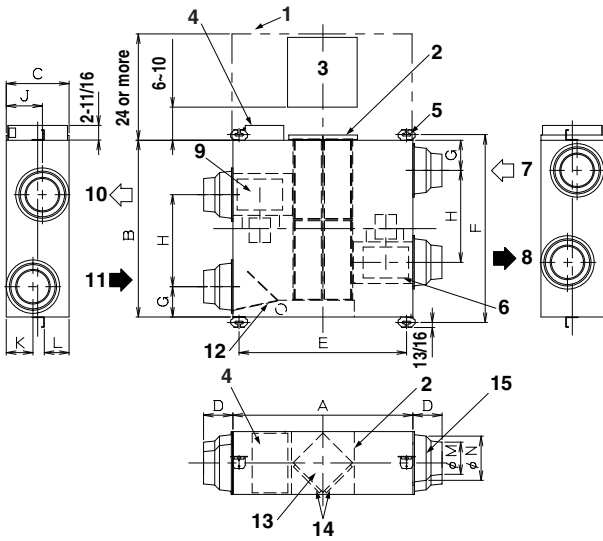

(in.)

Model name	A	B	C	D	E	F	G	H	J	K	L	M	N
VAM300GVJU	34-5/8	31-1/2	12-1/16	3-5/16	32-3/8	33-7/16	5-3/8	16-3/8	7-3/16	5-3/16	4-13/16	7-3/4	8-3/8
VAM470GVJU	43-11/16	32-3/4	15-1/4	3-1/2	40-11/16	34-3/4	6	16-15/16	9-1/4	6	6-7/16	9-11/16	10-3/8
VAM600GVJU	43-11/16	47-13/16	15-1/4	3-1/2	40-11/16	49-3/4	6	24-1/2	9-1/4	6	6-7/16	9-11/16	10-3-8
VAM1200GVJU	43-11/16	47-13/16	-	-	-	49-5/8	-	19-5/8	-	-	-	-	-

1

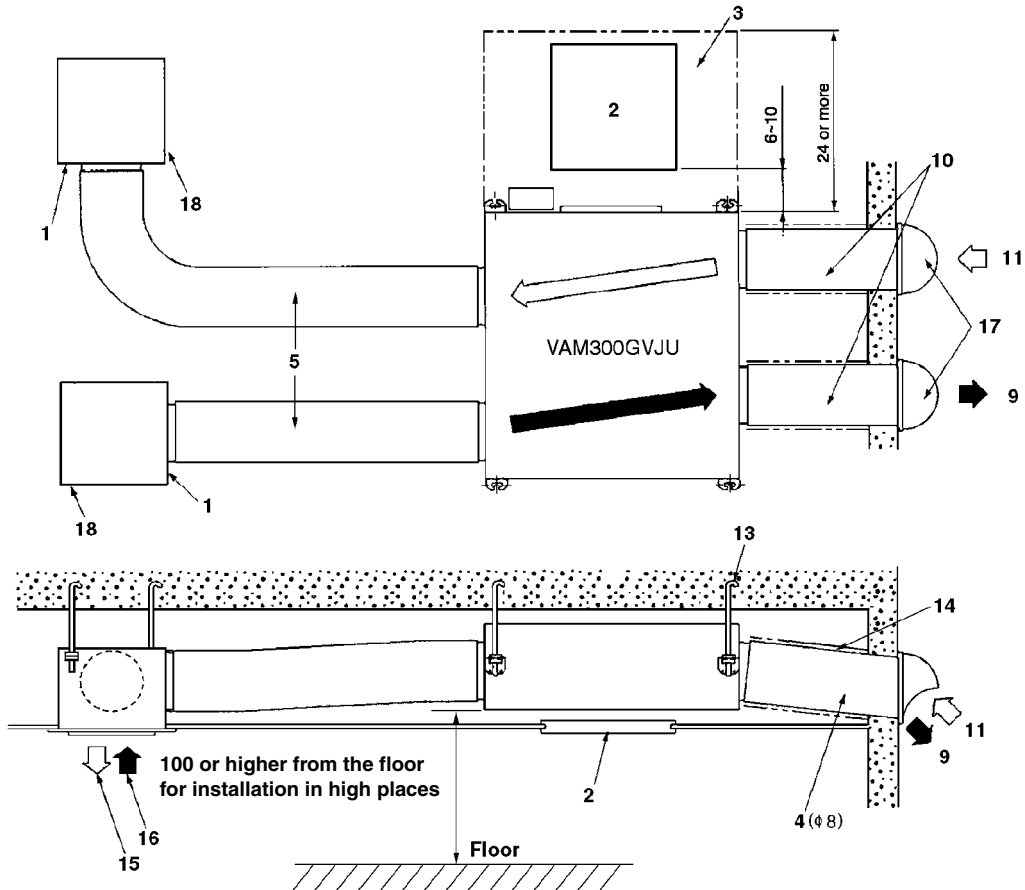

2

[1]

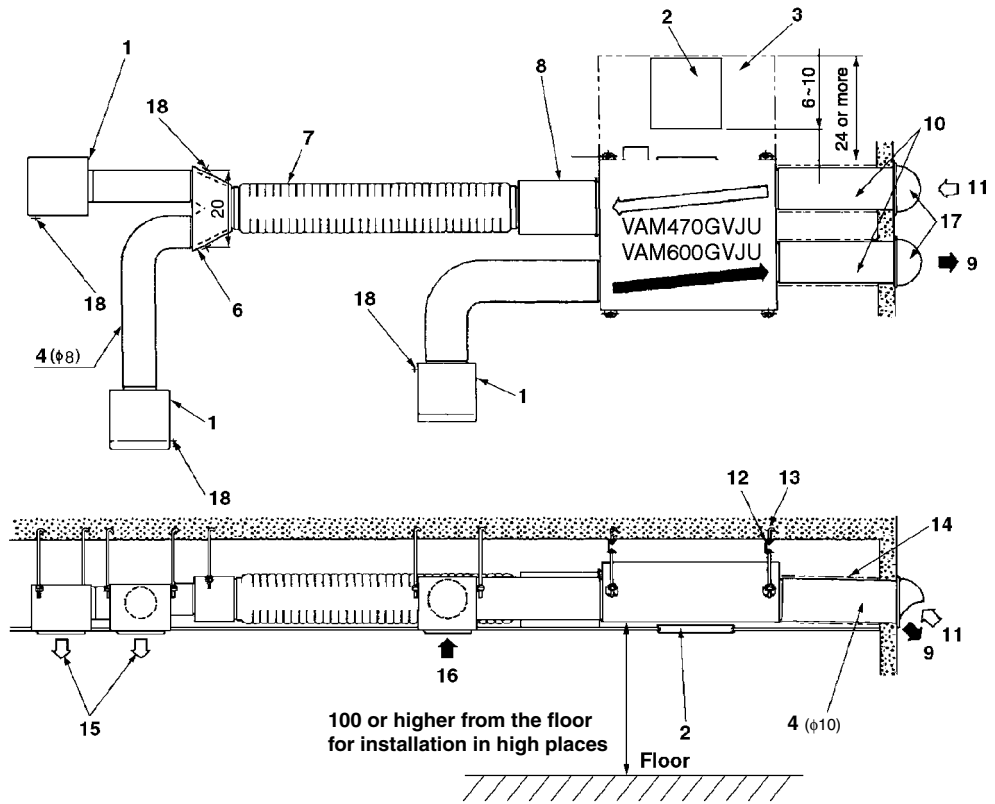

3

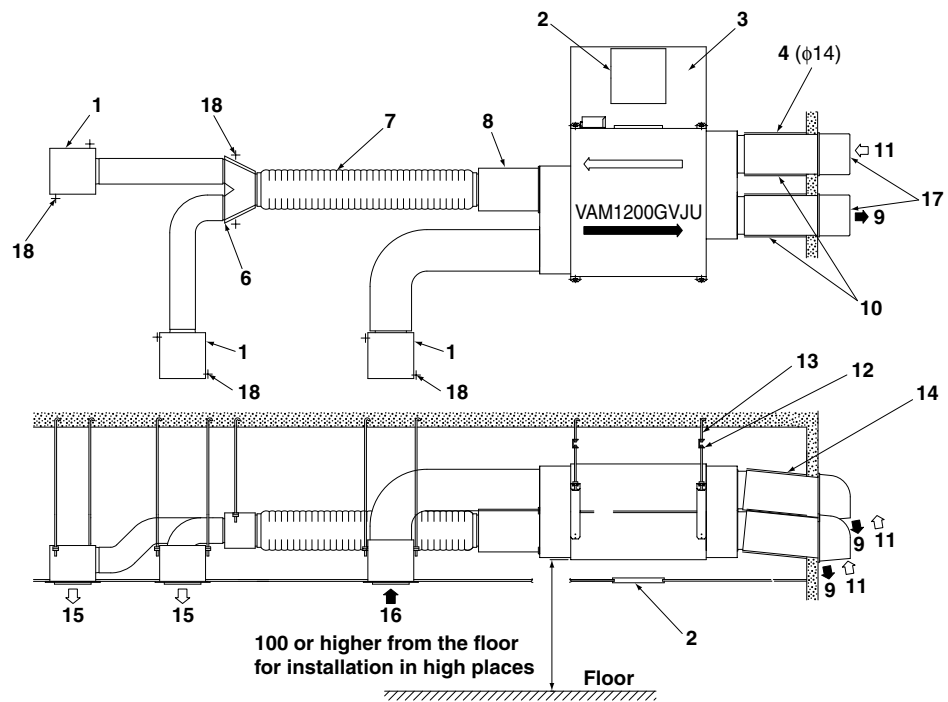

4

CONTENTS

1. SAFETY CONSIDERATIONS	1
2. BEFORE INSTALLATION	2
3. SELECTING INSTALLATION SITE	3
4. PREPARATIONS BEFORE INSTALLATION	3
5. THE METHOD OF INSTALLATION	4
6. DUCT CONNECTION	5
7. SYSTEM	6
8. ELECTRIC WIRING WORK	8
9. FIELD SETTING AND TEST RUN	13
10. DESCRIPTION OF SYSTEM AND APPLICABLE PATTERNS	15





1. SAFETY CONSIDERATIONS

Read these "SAFETY CONSIDERATIONS for Installation" carefully before installing the ERV unit. After completing the installation, make sure that the unit operates properly during a test run.

Instruct the customer on how to operate and maintain the unit. Inform the customer that this Installation Manual should be kept with the Operation Manual for future reference.

Always use a licensed installer or contractor to install this product. Improper installation can result in water or refrigerant leakage, electrical shock, fire or explosion.

Meanings of **DANGER**, **WARNING**, **CAUTION** and **NOTE** Symbols:

-  **DANGER**Indicates an imminently hazardous situation which, if not avoided, will result in death or serious injury.
-  **WARNING**Indicates a potentially hazardous situation which, if not avoided, could result in death or serious injury.
-  **CAUTION**Indicates a potentially hazardous situation which, if not avoided, may result in minor or moderate injury. It may also be used to alert against unsafe practices.
-  **NOTE**Indicates situations that may result in equipment or property-damage accidents only.

DANGER

- Do not ground units to water pipes, gas pipes, telephone wires or lightning rods as incomplete grounding can cause a severe shock hazard resulting in severe injury or death. Additionally, grounding to gas pipes could cause a gas leak and potential explosion causing severe injury or death.
- Do not install unit in an area where flammable materials are present due to risk of explosions that can cause serious injury or death.
- Safely dispose all packing and transportation materials in accordance with federal/state/local laws or ordinances. Packing materials such as nails, other metal or wood parts, including plastic packing materials used for transportation may cause injuries or death by suffocation.

WARNING

- Only qualified personnel must carry out the installation work. Installation must be done in accordance with this installation manual. Improper installation may result in water leakage, electric shock or fire.
- Use only specified accessories and parts for installation work. Failure to use specified parts may result in water leakage, electric shocks, fire or the unit falling.
- Install the unit on a foundation strong enough that it can withstand the weight of the unit. A foundation of insufficient strength may result in the unit falling and causing injuries.
- Take into account strong winds, typhoons or earthquakes when installing. Improper installation may result in the unit falling and causing accidents.
- Make sure that a separate power supply circuit is provided for this unit and that all electrical work is carried out by qualified personnel according to local state and national regulations. An insufficient power supply capacity or improper electrical construction may lead to electric shocks or fire.
- Make sure that all wiring is secured, that specified wires are used and that no external forces act on the terminal connections or wires. Improper connections or installation may result in fire.
- When wiring, position the wires so that the control box cover can be securely fastened. Improper positioning of the control box cover may result in electric shocks, fire or the terminals overheating.
- Before touching electrical parts, turn off the unit.
- Be sure to install a ground fault circuit interrupter if one is not already available. This helps prevent electrical shocks or fire.
- Do not change the setting of the protection devices. If the pressure switch, thermal switch or other protection device is shorted and operated forcibly, or parts other than those specified by Daikin are used, fire or explosion may occur.
- Locate the outdoor air intake vent so that it does not take in exhaust air which contains combustion air, etc. Incorrect installation may cause a loss of oxygen in the room, leading to serious accidents.
- Install the two outdoor ducts with down slope to prevent rainwater from entering the unit. If this is not done completely, water may enter the building, may damage furniture, and cause electric shocks and fire.
- Insulate the duct and the wall electrically when a metal duct is to be penetrated through the metal lattice and wire lattice or metal lining of a wooden structure wall. Improper duct work may cause electric shocks or fire.
- Make sure the temperature and humidity near the unit and the air suction/discharge air grille is within limit dictated by the usage conditions.
 1. Refrigerated truck or other locations with low temperatures.
 2. Place such as bathroom or heated pools subjected to moisture.
 This may cause fires or electric leak or electric shocks.
- Make sure that a snow protection measure is taken. If no protection snow may enter through the outdoor ducts, and cause damaging furniture and electric shock and fire.

CAUTION

- Do not touch the switch with wet fingers. Touching a switch with wet fingers can cause electric shock.
- Do not allow children to play on or around the unit to prevent injury.
- Be careful when transporting the product.
- Do not install the unit in the following locations:
 - (a) Where a mineral oil mist or oil spray or vapor is produced, for example, in a kitchen.
Plastic parts may deteriorate and fall off or result in water leakage.
 - (b) Where corrosive gas, such as sulfurous acid gas, is produced.
Corroding copper pipes or soldered parts may result in damage.
 - (c) Near machinery emitting electromagnetic waves.
Electromagnetic waves may disturb the operation of the control system and cause the unit to malfunction.
 - (d) Where flammable gas may leak, where there is carbon fiber or ignitable dust suspension in the air, or where volatile flammables such as thinner or gasoline are handled. Operating the unit in such conditions can cause a fire.
- Do not allow exhaust air to enter the outdoor air intake vent.
This may cause the air of the room to become contaminated, harming the health.

NOTE

- Install the power supply and control wires for the unit at least 3.3 feet away from televisions or radios to prevent image interference or noise. Depending on the radio waves, a distance of 3.3 feet may not be sufficient to eliminate the noise.
- Dismantling the unit and additional parts must be done in accordance with the relevant local, state and national regulations.
- This unit is an appliance that should not be accessible to the general public.
- Insulate the two outdoor ducts and the supply air duct to prevent condensation.
If this is not done completely, water may enter the building, may damage furniture, etc.
- In areas where insects are easily attracted to a light, such as where there is a window or light near a ventilation opening, extremely small insects can sometimes infiltrate the room by passing through the ventilation opening.
Since totally preventing against infiltration by extremely small insects is difficult, it is important to consider a serious solution like a filter box (field supply) during the design process to protect against insect infiltration.

2. BEFORE INSTALLATION

The accessories needed for installation must be retained in your custody until the installation work is completed. Do not discard them!

1. Decide upon a line of transport.
2. Leave the unit inside its packaging while moving, until reaching the installation site. Where unpacking is unavoidable, use a sling of soft material or protective plates together with a rope when lifting, to avoid damage or scratches to the unit.

Hold the unit by the hanger brackets (4) when opening the crate and moving it, and do not lift it holding on to any other part (especially the duct connecting flange).

2-1 PRECAUTIONS

- Be sure to instruct customers how to properly operate the unit (especially maintenance of air filter, and operation procedure) by having them carry out operations themselves while looking at the manual.
- Where the air contains high levels of salt such as that near the ocean and where voltage fluctuates greatly such as that in factories. Also in vehicles or vessels.



2-2 DIMENSIONS

- See figure 1 (All dimensions are in inches.)
 1. Service space for the heat exchanger cores, the air filters, control box and fans
 2. Service cover
 3. Inspection hatch (□18 in.)
 4. Control box
 5. Hanger bracket (7/16×1-9/16 in. oval hole)
 6. Exhaust fan
 7. OA (Outdoor air) Outdoor air from outside
 8. EA (Exhaust air) Exhaust air to outside
 9. Supply air fan
 10. SA (Supply air) Supply air to inside
 11. RA (Return air) Return air from inside
 12. Damper
 13. Heat exchanger core
 14. Air filters
 15. Duct connecting flange

Model name	Weight (LBS)	Applicable nominal diameter of duct [in.]
VAM300GVJU	71	φ8
VAM470GVJU	121	φ10
VAM600GVJU	148	φ10
VAM1200GVJU	346	φ14

2-3 ACCESSORIES

Check the following accessories are included with your unit.

Name	Duct connecting flange	M4 tapping screw (For connecting duct)	Wire harness for external damper operation
Quantity	4 pcs.	Refer to Table 1	1 pc.
Shape			



Name	Clamp	Insulation tube	(Other) • Installation manual • Operation manual
Quantity	5 pcs.	1 pc.	
Shape			

Table 1

Quantity of tapping screw

Model name	Quantity
VAM300GVJU	16 pcs.
VAM470GVJU, 600GVJU, 1200GVJU	24 pcs.

2-4 OPTIONAL ACCESSORIES

- This unit can be made a part of different systems: as part of the interlocking system used together with VRV System, and as an independent system using only the ERV. A remote controller is required for this unit when using the unit as an independent system.

Table 2

	Remote controller type
Interlocking system or independent system	BRC1E71

NOTE) 1

If you use a remote controller which is not listed in above table, please consult your dealer.

- When installing the unit, have ready a round shape hood, an air discharge grille and an air suction grille and other parts needed for the installation.

FOR THE FOLLOWING ITEMS, TAKE SPECIAL CARE DURING INSTALLATION AND CHECK AFTER INSTALLATION IS FINISHED.

a. Items to be checked after completion of work



Items to be checked	If not properly done, what is likely to occur	Check
Is the outdoor duct installed to outside with down slope?	Penetration of rain water may drip.	
Is the unit fully insulated?	Condensate water may drip.	
Does the power supply voltage correspond to that shown on the name plate?	The unit may malfunction or the components burn out.	
Is wiring correct?	The unit may malfunction or the components burn out.	
Is the unit safely grounded?	Dangerous at electric leakage.	
Is wiring size according to local, state or national codes?	The unit may malfunction or the components burn out.	
Is something blocking the air outlet or inlet of the unit?	It may result in insufficient ventilation or unusual operating noise.	

Please check all items listed in the "SAFETY CONSIDERATIONS" above once again.

b. Items to be checked at time of delivery

Items to be checked	Check
Did you explain about operations while showing the operation manual to your customer?	
Did you hand the operation manual over to your customer?	

c. Points for explanation about operations

The items with  WARNING and  CAUTION marks in the operation manual are the ones pertaining to possibilities for bodily injury and material damage in addition to the general usage of the product. Accordingly, it is necessary that you make a full explanation about the described contents and also ask your customers to read the operation manual.

3. SELECTING INSTALLATION SITE

 **CAUTION**

- When moving the unit during or after unpacking, make sure to lift it by holding its hanger brackets. Do not exert any pressure on other parts, especially duct connecting flange.
- Attach additional thermal insulation material to the unit body when it is believed that the temperature and the relative humidity in the ceiling exceed 86°F and 80%. Use glass wool, polyethylene foam, or similar with a thickness of 7/8 in. or more as thermal insulation material.

(1) Select an installation site where the following conditions are fulfilled and that meet with your customer's approval.

- Install in a place which has sufficient strength and stability. (Beams, ceiling and other locations capable of fully supporting the weight of the unit.) Insufficient strength is dangerous. It may also cause vibration and unusual operating noise.
- Where nothing blocks air passage.
- Do not install the unit directly against a ceiling or wall. (If the unit is in contact with the ceiling or wall, it can cause vibration.)
- Where sufficient clearance for maintenance and service can be ensured.

[PRECAUTION]

- Install the unit, power supply wiring and transmission wiring at least 40 in. away from televisions or radios in order to prevent image interference or noise. (Depending on the radio waves, a distance of 40 in. may not be sufficient enough to eliminate the electric noise.)
- The bellows may not be used in some districts, so exercise caution. (Contact your local government office or fire department for details.)

(2) Use suspension bolts for installation. Check whether the ceiling is strong enough to support the weight of the unit or not. If there is a risk, reinforce the ceiling before installing the unit.

(Installation pitch is mentioned as follows. Refer to it to check for points requiring reinforcing.)

4. PREPARATIONS BEFORE INSTALLATION

(1) Confirm the positional relationship between the unit and suspension bolts. (Refer to figure 1)

Leave space for servicing the unit and include an inspection hatch. (Always open a hole on the side of the control box so that the air filters, heat exchanger cores and fans can be easily inspected and serviced.)

(2) Make sure the range of external static pressure is not exceeded.

(See the fan speed and static pressure performance characteristic drawing as well as the general catalog for the range of the external static pressure setting.)

(3) Open the installation hole. (Pre-set ceilings)

- Once the installation hole is opened in the ceiling where the unit is to be installed, pass transmission wiring and remote controller wiring to the unit's wiring hole. See "8-2 WIRING EXAMPLE".
- After opening the ceiling hole, make sure ceiling is level if needed. It might be necessary to reinforce the ceiling frame to prevent shaking. Consult an architect or carpenter for details.

(4) Install the suspension bolts.

(Use 1/2"UNC suspension bolts.)

Use a hole-in-anchor, sunken insert, sunken anchor for existing ceilings, or other part to be procured in the field to reinforce the ceiling to bearing the weight of the unit.

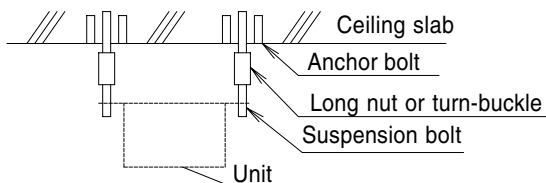

Note: All the above parts are field supply.

5. THE METHOD OF INSTALLATION

⟨⟨As for the parts to be used for installation work, be sure to use the provided accessories and specified parts designated by Daikin.⟩⟩

- Example of Installation, VAM300GVJU (See figure 2), VAM470GVJU, VAM600GVJU (See figure 3), VAM1200GVJU (See figure 4)
 1. Air suction/discharge grille (field supply)
 2. Inspection hatch (18 in.) (field supply)
 3. Service space for the heat exchanger cores, air filters, control box and fans
 4. Duct (field supply)
 5. Duct (field supply) or flexible duct (field supply)
 6. Branch duct (field supply) (only for VAM470GVJU~1200GVJU)
 7. Flexible duct (field supply)
 8. Silencer (field supply)
 9. EA (Exhaust air to outside)
 10. Thermal insulation (field supply)
 11. OA (Outdoor air from outside)
 12. Suspension bracket for absorbing vibration (field supply)
 13. Suspension bolt (field supply)
 14. Gradient of down to outside $\geq 1/30$
 15. SA (Supply air to inside)
 16. RA (Return air from inside)
 17. Round hood (field supply)
 18. Suspension bolt position

<Cautions on installing the ducts>

- When using the unit at a quiet place, use a silencer (field supply) and flexible duct (field supply) at the part of the air discharge outlet on the indoor side "SA" (supply air to inside) of the unit to counter the noise.
- When selecting installation materials, consider the required volume of airflow and noise level in that particular installation.
- When the outdoor air infiltrates into the ceiling and the temperature and humidity in the ceiling become high, insulate the metal portions of the unit.

(1) Attach duct connecting flange

<VAM300GVJU>

Attach the 4 included duct connecting flanges using the included screws.

Match the symbol on the duct joints (the triangle \triangle on the flange) to the position marking on the unit when attaching.

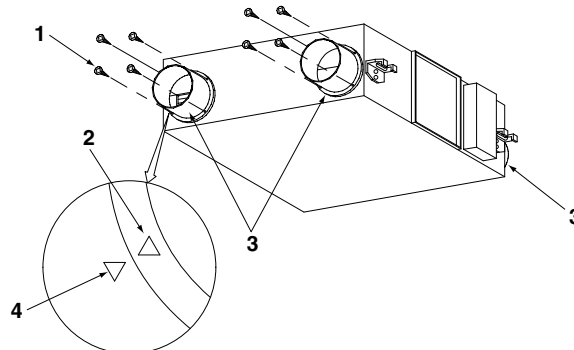

<VAM470GVJU, VAM600GVJU, VAM1200GVJU>

Attach the 4 included duct joints using the included screws.

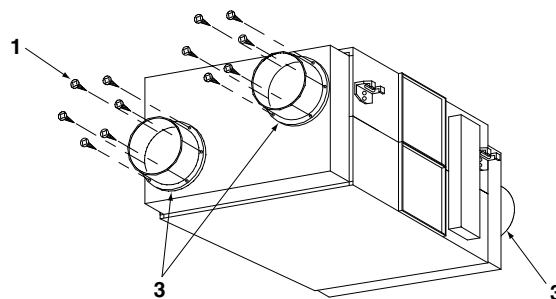

[In case of VAM1200GVJU]

1. Screw
2. Duct joint symbol
3. Duct connecting flange
4. Unit position marking

Model	Number of screws
VAM300GVJU	16
VAM470GVJU	24
VAM600GVJU	24
VAM1200GVJU	24

(2) Installing the unit

Pass hanger bracket over the bolts and secure with commercially available washers and nuts.

(When installing the unit, make sure there are no foreign objects (plastic, paper, etc.) inside the fan housing by looking inside through the duct hole before connecting the duct.)

- When reversing the hanger brackets in order to install the unit upside down, be sure to secure them with the original screws.
- Attach the indoor (SA, RA) and outdoor (EA, OA) ducts by referring to figure 2 to 4.

<VAM300GVJU, VAM470GVJU, VAM600GVJU>

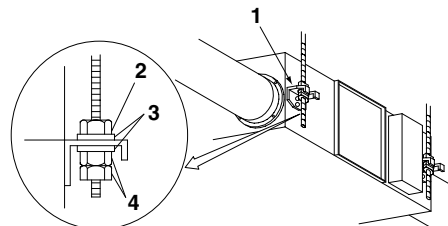

<VAM1200GVJU>

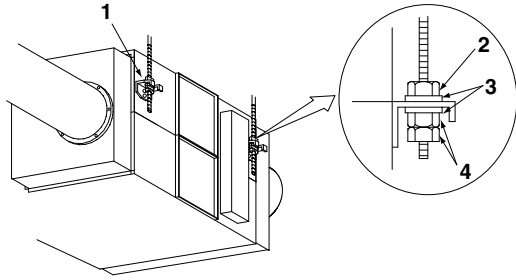

- 1. Hanger bracket
- 2. Nut
- 3. Washer
- 4. Double nuts

6. DUCT CONNECTION

<Perform duct work by following instructions below>

1. Do not connect the ducts as shown below.

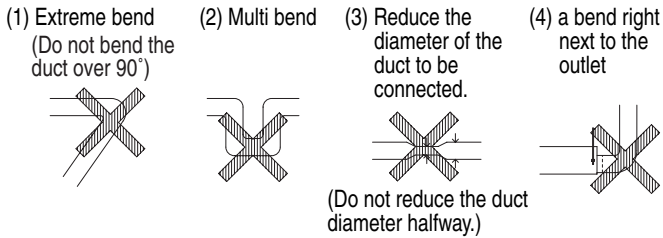

2. The minimum radius of bends for flexible ducts are as follows.

- 4 in. diameter duct : 4 in.
- 6 in. diameter duct : 6 in.
- 8 in. diameter duct : 12 in.
- 10 in. diameter duct : 15 in.

3. To prevent air leakage, wind aluminum tape round the section after the duct connecting flange and the duct are connected. (Refer to the figure below.)

4. To prevent air leakage, install the opening of the indoor air intake as far as from the opening of the exhaust suction.

5. Use the duct applicable to the unit used (Refer to figure 1.)

6. Install the two outdoor ducts with down slope (slope of 1/30 or more) to prevent entry of rain water. Also, provide insulation for both ducts to prevent dew formation. (Material : Glass wool of 1 in. thick)

If the unit is going to be used in cold places where the outside temperature reaches 14°F or below, insulate the indoor ducts as well.

7. If the level of temperature and humidity inside the ceiling is always high, install a ventilation equipment inside the ceiling.

8. Insulate the duct and the wall electrically when a metal duct is to be penetrated through the metal lattice and wire lattice or metal lining of a wooden structure wall.

9. Using flexible or silent ducts can be effective in reducing the air discharge sound of the supply air to inside (SA). Select materials keeping in mind the fan speed and operating sound of the unit. Consult your Daikin dealer for selection.

10. Set the pitch between the exhaust air outlet (EA) and the outdoor air intake (OA) to at least 3 times the duct diameter.

11. Do not use a bent cap or a round hood as the outdoor hood if they might get rained on directly. (We recommend using a deep hood (field supply).)

12. When using a deep hood, make sure the duct from the deep hood (outer wall) to the unit is at least 40 in. long.

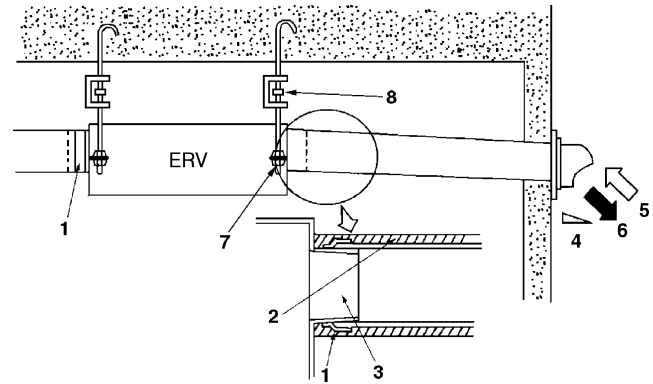

Select the proper materials taking fan speed and noise levels into consideration before installation.

- 1. Aluminum tape (field supply)
- 2. Insulation material (field supply)
- 3. Duct connecting flange (accessory)
- 4. Slope over 1/30
- 5. OA (Outdoor air) Outdoor air from outside
- 6. EA (Exhaust air to outside)
- 7. Suspension bolt (field supply)
- 8. Suspension bracket for absorbing vibration (field supply)

7. SYSTEM

7-1 Independent system Interlocking system with VRV or SkyAir system

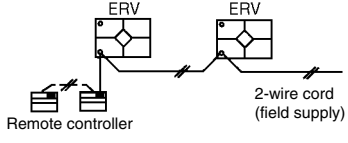
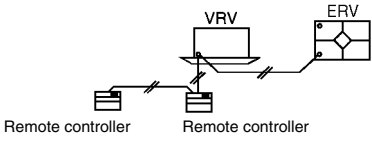
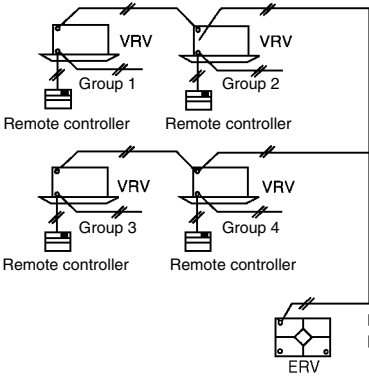
SYSTEM		Standard method	Related items in Electric wiring	
Independent system		<ul style="list-style-type: none"> Up to 16 units can be controlled with the remote controller. (A system with two remote controls can be created in the main/sub setting.) All ERV operations can be used and indicated. Operation monitor output and humidifier operation are possible using the Adapter PCB. Remote control cord should be field supply. (Maximum cord length : 1640 ft.) 	10-1-1	
Interlocking system with VRV or SkyAir system	1-group linked operation system		<ul style="list-style-type: none"> A combined total of up to 16 air conditioners and the ERV can be controlled. The ERV mode can be operated independently when air conditioners are not being used. Using the field setting of the remote controller for air conditioners, various settings such as pre-cool/pre-heat reservation on/off, ventilation rate, ventilation mode, etc. 	10-2-1
	Multi-group (2 or more) linked operation system		<ul style="list-style-type: none"> Since all VRV units are connected to a single line in view of installation, all VRV units are subjects for operation. If there are problems operating all VRV units, do not use this system. 	10-2-3

NOTE

- Adapter PCB : KPR50-2 ; Installation box for adapter PCB : KRP50-2A90
- Operation of two or more group is not possible with a direct duct connection as below.
- The direct duct connection can also be selected for 1-group linked operation system.

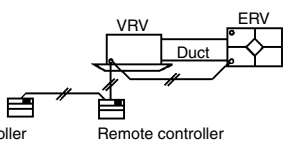
SYSTEM		Standard method	Related items in Electric wiring
Direct duct connection system		<ul style="list-style-type: none"> The ERV operates only when the air conditioner fan is ON. When the air conditioner is not being used, the ERV can be operated in circulation or ventilation modes. Other specifications are the same as those of the standard system. 	10-2-2

7-2 CENTRALIZED CONTROL SYSTEM (VRV SYSTEM)

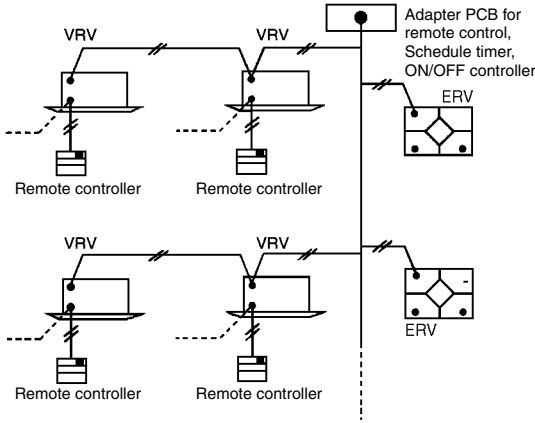
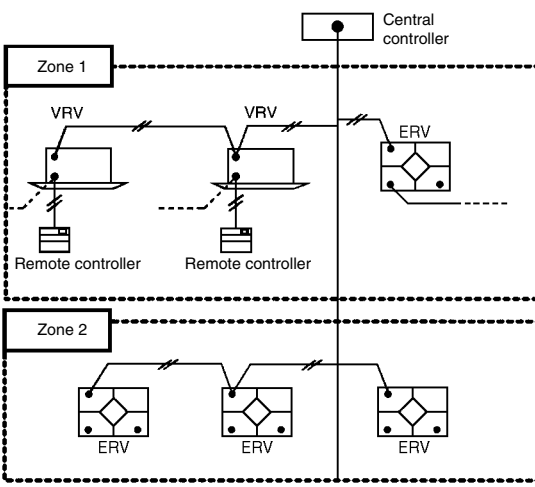
SYSTEM		Standard method	Related items in Electric wiring
Centralized control system	<p>"All"/individual control system</p> 	<ul style="list-style-type: none"> • Use of the ON/OFF controller, Adapter PCB for remote control or Schedule timer enables centralized control of the entire system. (maximum of 64 groups) • The ON/OFF controller can turn on or off the individual units. • The schedule timer and ON/OFF controller can be used together. However, the Adapter PCB for remote control cannot be used with another centralized control device. 	10-3-2
	<p>Zone control system</p> 	<ul style="list-style-type: none"> • Use of the centralized controller enables zone control via the centralized control line. (maximum of 64 zones) • The centralized controller displays the "Filter" indication and abnormality warnings, and enables resetting. • The centralized controller allows ventilation operation for each zone independently. 	10-3-3

[Caution]

(1) Adapter PCB : KRP50-2, schedule timer DST301BA61, ON/OFF controller. DCS301C71, Central remote controller: DCS302C71

8. ELECTRIC WIRING WORK

- Shut off the power supply before doing any work.
- All field supplied parts, materials and electric works must conform to local codes.
- Use copper wire only.
- All wiring must be performed by an authorized electrician.
- See also the “Wiring Diagram label” attached to the control box cover when laying electrical wiring.
- Wire the remote controller as shown in the wiring diagram label. See the “Remote Controller Installation Manual” for details on how to install and lay the wiring for the remote controller.
Install a ground fault circuit interrupter for the power supply wiring.
- Make sure the ground resistance is no greater than 100Ω . This value can be as high as 500Ω when using a ground fault circuit interrupter since the protective ground resistance can be applied.
- Do not let the ground wire come in contact with gas pipes, water pipes, lightning rods, or telephone ground wires.
 - Gas pipes: gas leaks can cause explosions and fire.
 - Water pipes: cannot be grounded if hard vinyl pipes are used.
 - Telephone ground and lightning rods: the ground potential when struck by lightning gets extremely high.
- Do not turn on the power supply (wiring interrupter or ground fault circuit interrupter) until all other work is done.
- Use vinyl cord with sheath or cable (2 wire) of AWG18-16 for transmission wiring.

⚠ CAUTION

Before obtaining access to terminal devices, all power supply circuits must be interrupted.

8-1 PRECAUTIONS WHEN LAYING POWER SUPPLY WIRING

[PRECAUTION]

1. A circuit breaker capable of shutting down power supply to the entire system must be installed.
2. A single switch can be used to supply power to units on the same system. However, branch switches and branch circuit breakers must be selected carefully.
3. Fit the power supply wiring of each unit with a disconnect switch as shown in the drawing below.
4. Be sure to give the electric grounding connection.
5. Tightening torque for the terminal screws.
 - Use the correct screwdriver for tightening the terminal screws. If the blade of screwdriver is too small, the head of the screw might be damaged, and the screw will not be properly tightened.
 - If the terminal screws are tightened too hard, screws might be damaged.
 - Refer to the table below for the tightening torque of the terminal screws.

	Tightening torque (ft-lbf)
Terminal block for remote controller/ Transmission wiring (X2M)	0.59 – 0.71
Power supply terminal block (X1M)	0.88 – 1.06
Ground terminal (M4)	1.07 – 1.43

6. Connect round crimp-style terminals provided with insulation sleeves to the terminal block for power supply. Be sure to follow the instructions provided below if the specified terminals cannot be used.
Otherwise, abnormal heat may be generated as a result of the loosening of the wires.

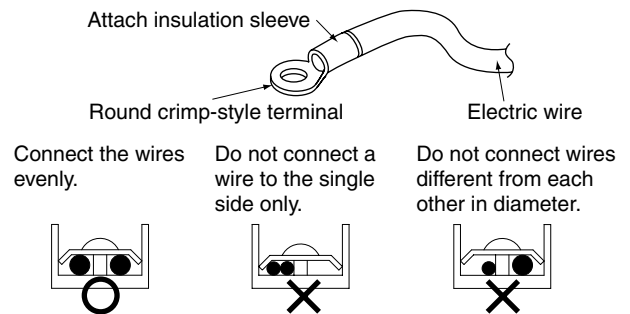

7. Do not connect wires of different gauge to the same grounding terminal. Looseness in the connection may deteriorate protection.
8. Keep the power supply wiring distant from other wires to prevent noise.

COMPLETE SYSTEM EXAMPLE

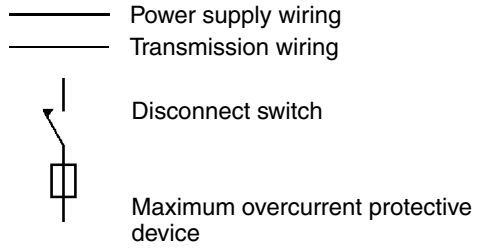
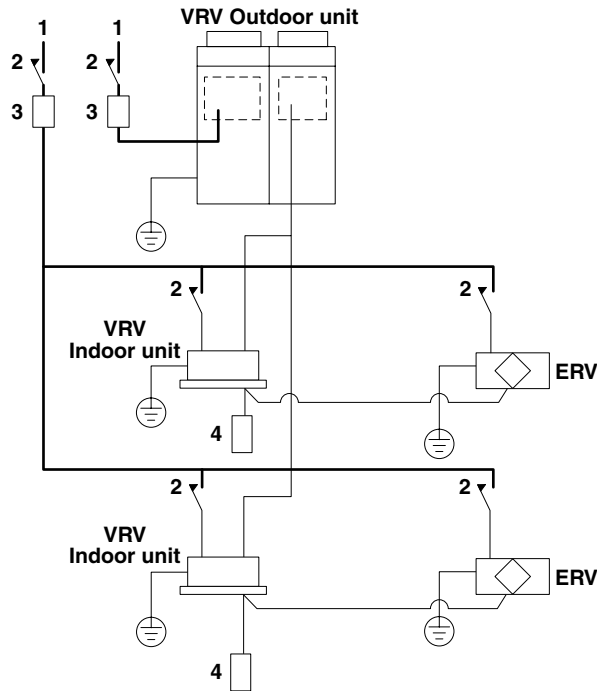

- 1. Power supply
- 2. Disconnect switch
- 3. Maximum overcurrent protective device
- 4. Remote controller

1. Component electrical specifications

Units		Power supply		Fan motor		
Model		Voltage range	MCA	MOP	KW	FLA
VAM300GVJU	Single phase 208/230V 60 Hz	Max.253V Min.187V	1.6	15	0.09 × 2	1.4
VAM470GVJU			3.9	15	0.28 × 2	3.5
VAM600GVJU			4.2	15	0.28 × 2	3.7
VAM1200GVJU			8.1	15	0.28 × 4	7.6

Symbol) MCA: Minimum Circuit Ampacity (A)
 MOP: Maximum Overcurrent Protective Device (A)
 KW: Motor Rated Output (kW)
 FLA: Full Load Ampacity (A)

NOTE

1. When using a ground fault circuit interrupter, make sure to select one useful also to protection against overcurrent and short-circuit.
2. The length of the transmission wiring and remote controller wiring are as follows.
 - Length of outdoor-indoor transmission wiring ... max 3280 ft. (total wiring length 6560 ft.)
 - Length of remote controller wiring between indoor unit and remote controller ... max 1640 ft.

8-2 WIRING EXAMPLE

CAUTION

Before opening the control box, be sure to turn off the power supply of the units and other devices connected with the units.

<OPENING THE CONTROL BOX>

1. Remove the screws fixing the cover and open the control box as shown below.
2. Secure the power supply wiring and the transmission wiring with the clamp, as shown in 8-2.

<VAM300GVJU, VAM470GVJU, VAM600GVJU>

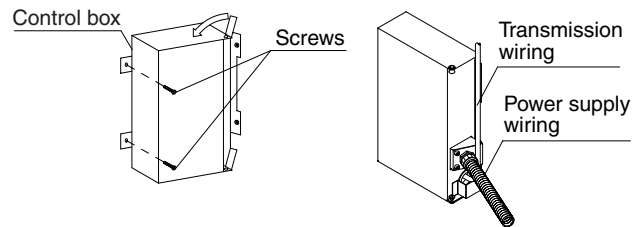

<VAM1200GVJU>

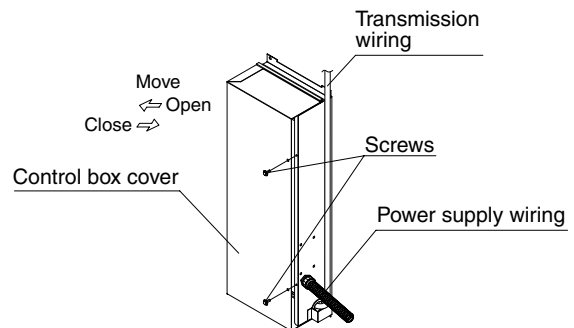

CAUTION

If the unit is installed upside down, be sure to use a liquid-tight connector of conduit for power supply and ground wiring to prevent water from infiltrating.

<FIX THE CONDUIT (FIELD SUPPLY)>

<VAM300GVJU, VAM470GVJU, VAM600GVJU>

- To make a conduit connection for power supply and ground wiring, remove the screws and detach the conduit fixing plate from the control box.
- Attach the conduit to the conduit fixing plate and fasten it with a conduit locknut.
- Then, put them back to the original position with the screws.

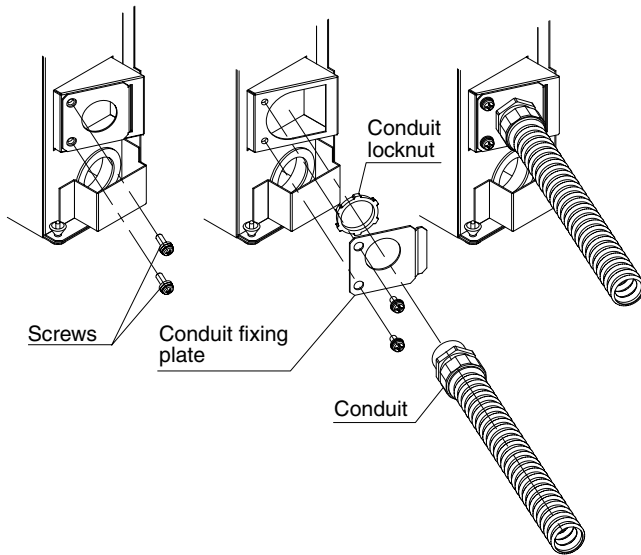

<VAM1200GVJU>

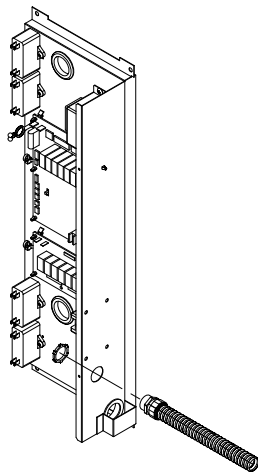

NOTE

In case of installing the optional Adapter PCB the installation box (option) is needed. See 8-4 on how to install it.

<WIRING PROCEDURE>

<VAM300GVJU, VAM470GVJU, VAM600GVJU>

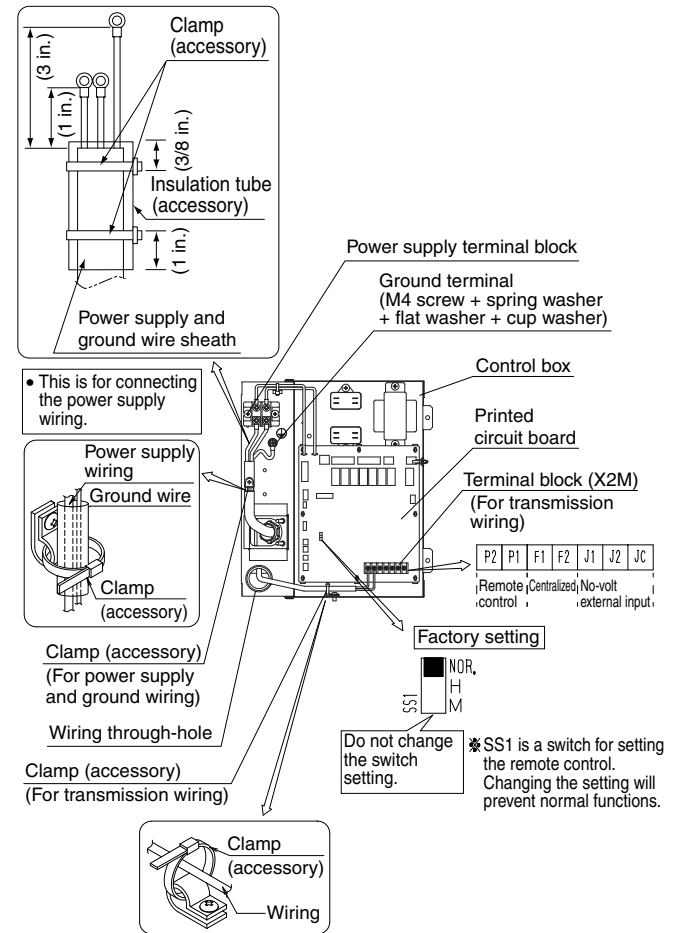

<VAM1200GVJU>

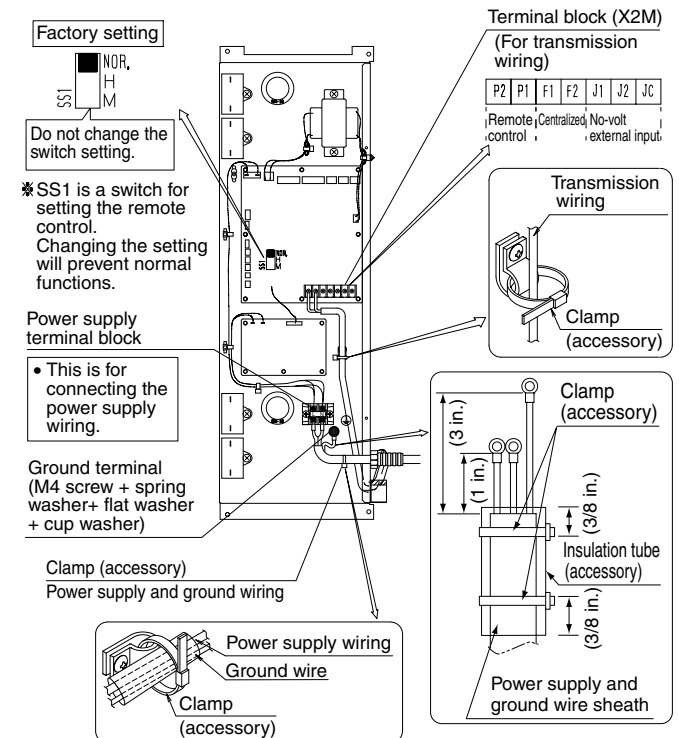

CAUTION

- Use an appropriate screwdriver for tightening the terminal screws.
A screwdriver with a small head will damage the head and make proper tightening impossible.
Over-tightening the terminal screws may break them. See the table for the tightening torque of the terminal screws shown in 8-1.
- Be sure to attach sealing material or putty (field supply) to the hole of wiring to prevent the infiltration of water as well as any insects and other small creatures from outside. Otherwise a short-circuit may occur inside the control box.
- When clamping the wires, be sure no pressure is applied to the wire connections by using the included clamp to make appropriate clamps. Also, when wiring, make sure the control box cover fits snugly by arranging the wires neatly and attaching the control box cover firmly.
When attaching the control box cover, make sure no wires get caught in the edges. Pass wiring through the wiring through holes to prevent damage to them.
- Make sure the remote controller wiring, the wiring between the units and other electrical wiring do not pass through the same locations outside of the unit, separating them by at least 2 in., otherwise electrical noise (external static) could cause mistaken operation or breakage.

3. Be sure to connect a ground wire.

<Precautions when connecting a ground wire>

When pulling the ground wire out, wire it so that it comes through the cut out section of the cup washer.
(An improper ground connection may prevent a good ground from being achieved.)

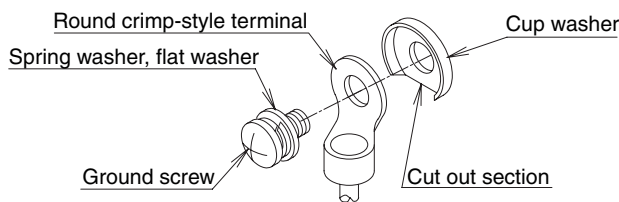

4. Be sure to connect the remote control wiring and the transmission wiring to the terminals on the X2M terminal block.

[PRECAUTIONS]

- Refer to the "Remote Controller Installation Manual" on how to install and lay the wiring for the remote controller.
- Do not, under any circumstances, connect the power wiring to the remote controller or transmission wiring terminal block.
Doing so can destroy the entire system.
- Connect the remote controller and transmission wiring their respective terminal blocks.
- Use shield wire in transmission wiring. Ground the shield of the shield wire to "⏏", at the grounding screw, with the cup washer.

8-3 Power supply connection, transmission wire terminals and switches on the printed circuit board

- Connect the power supply to the L1 and L2 terminals.
- Secure the power supply with the power cord clamp.
- Be sure to give a grounding connection.

<VAM300GVJU, VAM470GVJU, VAM600GVJU>

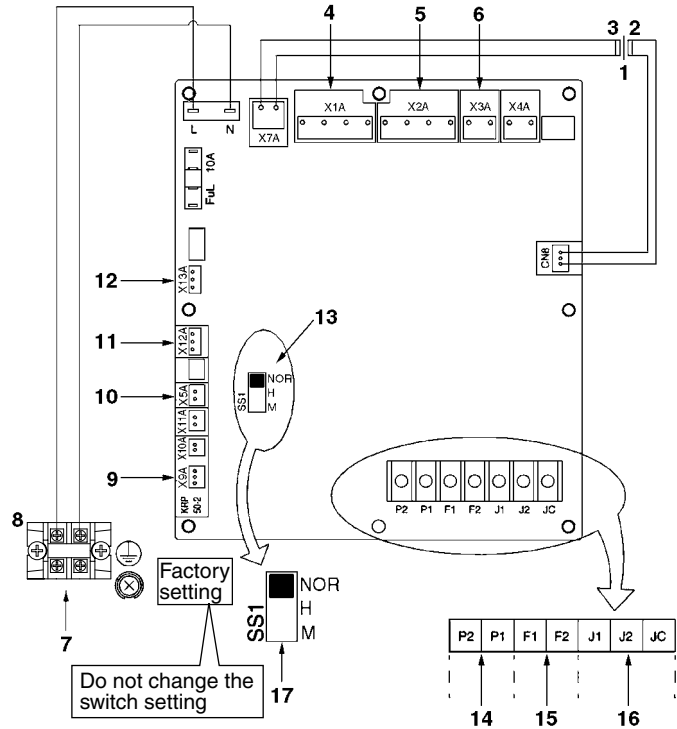

<VAM1200GVJU>

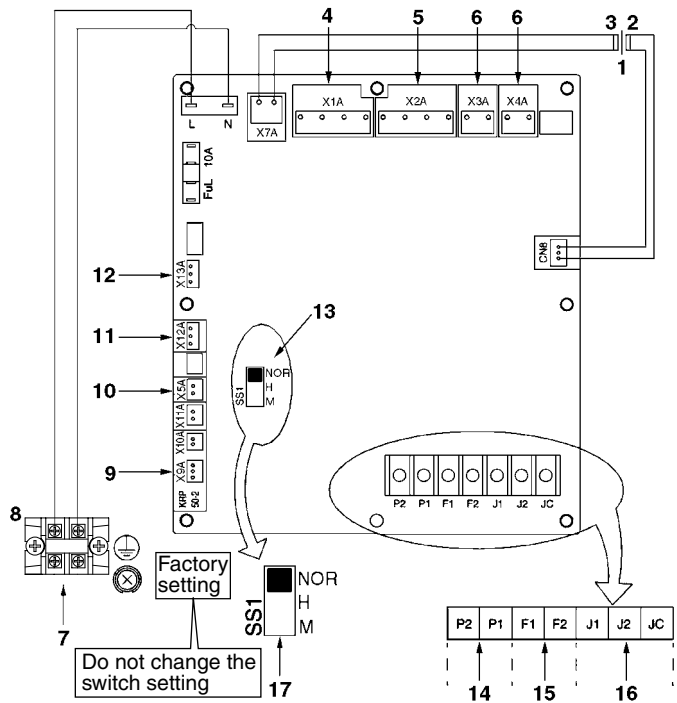

- | | |
|---------------------------------------|---|
| 1. Transformer | 10. Connector for limit switch |
| 2. Secondary | 11. Connector for indoor air thermistor |
| 3. Primary | 12. Connector for outdoor air thermistor |
| 4. Connector for supply air fan motor | 13. Selector switch |
| 5. Connector for exhaust fan motor | 14. Terminals for remote controller |
| 6. Connector for damper motor | 15. Terminals for centralized control |
| 7. Power supply | 16. Terminals for no-voltage external input |
| 8. Terminal block | 17. Factory setting |
| 9. Connector for KPR50-2 | |

8-4 How to install the optional Adapter PCB (KRP4A72, KRP50-2)

<VAM300GVJU, VAM470GVJU, VAM600GVJU>

- When installing the optional adaptor PCB, it is necessary to prepare the fixing box (KRP50-2A90)
 1. Open the control box cover by following the procedure described in the "8-2" <OPENING THE CONTROL BOX> section.
 2. Remove the screws and install the adapter PCB.
 3. After wiring, fasten the control box cover.

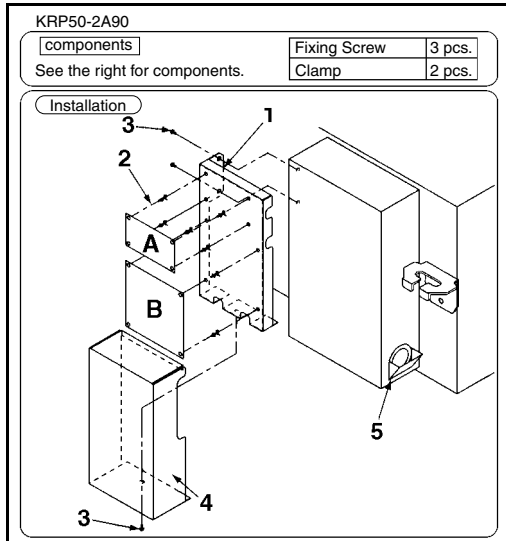

1. Fixing board
2. PCB support
(Attached to adapter PCB)
3. Fixing screw
4. Cover
5. Control box

	Applicable adapter name	Kit name	Fixing box
A	Adapter PCB for Humidifier	KRP50-2	KRP50-2A90
B	Adapter PCB for remote controll	KRP4A72	KRP50-2A90

<VAM1200GVJU>

- When installing the optional adaptor PCB, it is necessary to prepare the fixing box (KRP50-2A90)
 1. Open the control box cover by following the procedure described in the "8-2" <OPENING THE CONTROL BOX> section.
 2. Remove the screws and install the adapter PCB.
 3. After wiring, fasten the control box cover.
- The adapter circuit board (KRP50-2) can be installed on the inner right-hand side of the control box.
The attachment box (optional accessory) is not required.

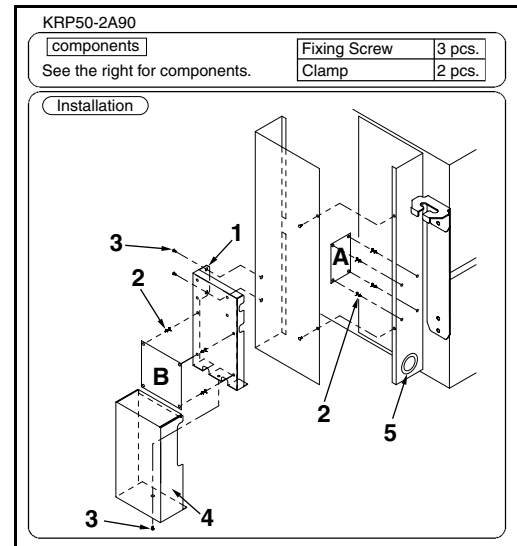

1. Fixing board
2. PCB support
(Attached to adapter PCB)
3. Fixing screw
4. Cover
5. Control box

	Applicable adapter name	Kit name	Fixing box
A	Adapter PCB for Humidifier	KRP50-2	KRP50-2A90
B	Adapter PCB for remote control	KRP4A72	KRP50-2A90

9. FIELD SETTING AND TEST RUN

9-1 Press and hold Cancel button for 4 seconds or longer.

Service settings menu is displayed.

9-2 Select "Field Settings" in the Service Settings menu, and press Menu/OK button.

Field settings screen is displayed.

9-3 Highlight the mode and select desired "Mode No." by using ▲▼ (Up/Down) button.

9-4 In the case of setting per unit during group control (When Mode No. such as "20", "21", "22", "23", "25" are selected), highlight the unit No. and select "Indoor unit No." to be set by using ▲▼ (Up/Down) button.

(In the case of group total setting, this operation is not needed.)

In the case of individual setting per unit, current settings are displayed. And, SECOND CODE NO. " - " means no function.

9-5 Highlight SECOND CODE NO. of the FIRST CODE NO. to be changed and select desired "SECOND CODE NO." by using ▲▼ (Up/Down) button. Multiple identical mode number settings are available.

In case of setting for all units in the remote control group, available SECOND CODE NO. is displayed as " * " which means it can be changed.

When SECOND CODE NO. is displayed as " - ", there is no function.

9-6 Press Menu/OK button. Setting confirmation screen is displayed.

9-7 Select "Yes" and press Menu/OK button. Setting details are determined and field settings screen returns.

9-8 In the case of multiple setting changes, repeat "9-3" to "9-7".

9-9 After all setting changes are completed, press Cancel button twice.

9-10 Backlight goes out and "Checking the connection. Please stand by." is displayed for initialization. After the initialization, the basic screen returns.

<Basic screen>

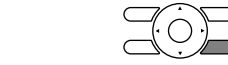
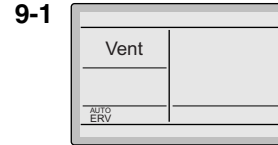

Press and hold Cancel button for 4 seconds or longer during backlight lit.

<Service Settings menu screen>

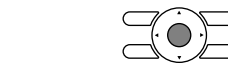
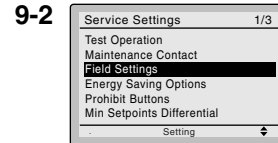

Press Menu/OK button.

<Service Settings menu screen>

In the case of individual setting per unit

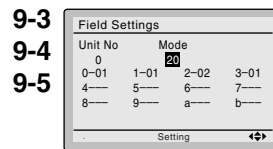

9-3
9-4
9-5

In the case of group total setting

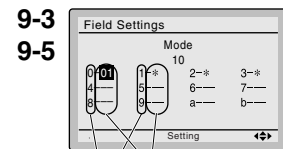

9-3
9-5

SECOND CODE NO.
FIRST CODE (SW) NO.

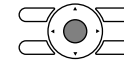

Press Menu/OK button.

<Setting confirmation screen>

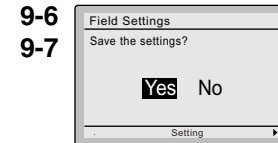

9-6
9-7

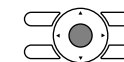

Press Menu/OK button.

Setting confirmation

List of Settings

Mode No.		FIRST CODE NO.	Description of Setting	SECOND CODE NO. (NOTE 1)					
Group settings	Individual settings			01	02	03	04	05	06
17	27	0	Filter cleaning time setting	Approx. 2500 hours	Approx. 1250 hours	No counting	–	–	–
		1	Nighttime free cooling operation start time (after other air conditioners operating together with the unit have been stopped)	Off	2 hours	4 hours	6 hours	8 hours	–
		2	Pre-cool/pre-heat on/off setting	Off	On	–	–	–	–
		3	Pre-cool/pre-heat time setting	30 min	45 min	60 min	–	–	–
		4	Fan speed initial setting	Normal	Extra high	–	–	–	–
		5	Yes/No setting for direct duct connection with VRV system	No duct (Airflow setting)	With duct (fan off)	–	–	–	–
				Setting for cold areas (Fan operation selection for heater thermo OFF)	–	–	No duct		With duct
						Fan off	Fan L	Fan off	Fan L
		7	Centralized/individual setting	Centralized	Individual	–	–	–	–
8	Centralized zone interlock setting	No	Yes	–	–	–	–		
9	Pre-heat time extension setting	0 min	30 min	60 min	90 min	–	–		
18	28	0	External signal JC/J2	Last command	Priority on external input	Priority on operation	–	–	–
		1	Setting for direct Power ON	Off	On	–	–	–	–
		2	Auto restart setting	Off	On	–	–	–	–
		3	External damper operation	–	–	On	–	–	–
		4	Indication of ventilation mode/Not indication	Indication	No Indication	–	–	–	–
		7	Fresh up air supply/exhaust setting	No Indication	No Indication	Indication	Indication	–	–
				Supply	Exhaust	Supply	Exhaust	–	–
		8	External input terminal function selection (between J1 and JC)	Fresh up	Overall alarm	Overall malfunction	Forced off	Fan forced off	Airflow increase
9	KRP50-2 output switching selection (between 1 and 3)	Fan on/off	Abnormal	–	–	–	–		
19	29	8	Electric heater setting	No delay	Exchange	On, off delay	On, off delay	–	–
1a	–	0	“Fresh up” on/off setting	Off	On	–	–	–	–

NOTE)

- The setting positions within the bolded cell “” are factory setting.
- The settings are applied to the entire group, but if the mode No. individual settings is selected, the settings can be applied to individual unit.
However, it is only possible to check any changes made to individual setting in individual mode. (For group control, the changes are made but the display remains as it was when shipped from the factory.)
- Do not set anything not shown above. If the applicable functions are not available, they will not be displayed.
- Group number setting for centralized controller
 - Mode No. 00: Group controller
 - Mode No. 30: Individual controller

* Regarding the setting procedure, refer to the section “Group number setting for centralized control” in the operating manual of either the ON/OFF controller or the central controller.

9-11 Perform a test run.

- (1) Before turning on the power supply, be sure to check that the control box cover is closed.
- (2) Perform a test run according to "OPERATION MANUAL".
 - An error code is displayed on the remote controller when a malfunction occurs. Check the error code on the display to identify the point of trouble. An explanation of error codes and the corresponding trouble is provided in "OPERATION MANUAL".
 If the display shows any of the following, there is a possibility that the wiring was done incorrectly or that the power supply is not ON, so check again.

Remote controller display	Content
U8	<ul style="list-style-type: none"> • Incorrect setting the MAIN/SUB of the remote controller.
No display	<ul style="list-style-type: none"> • The power supply to the unit is off. • The indoor unit and/or ERV have not been wired for power supply. • Incorrect wiring for the remote controller, the transmission wiring and / or the FORCED OFF wiring. • The remote controller wiring is disconnected. • Incorrect setting the "SS1" switch of PC board.

10. DESCRIPTION OF SYSTEM AND APPLICABLE PATTERNS

10-1 INDEPENDENT SYSTEM

10-1-1 When connecting to remote controller

(Refer to "9. FIELD SETTING AND TEST RUN".)

Check the switch "SS1" on the PC board to the factory setting.

Factory Setting



Do not change the switch setting.

※SS1 is a setting switch for special purposes. Changing the setting will stop the unit from operating normally.

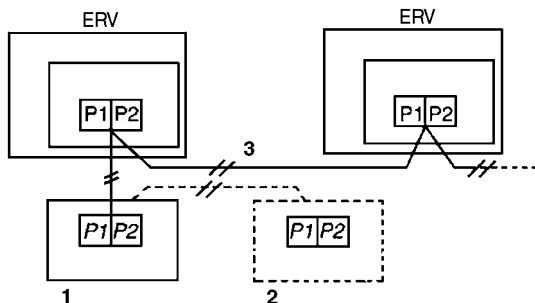

1. Main remote controller
2. Sub remote controller
3. Maximum transmission wiring length : 1640 ft.

10-2 Interlocking system with VRV system

10-2-1 Standard 1-group linked operation system

- The remote control can be used to control up to 16 air conditioner indoor units and ERV units.
 - Initial settings can be made for the functions of the ERV units (pre-cool/pre-heat, ventilation rate, ventilation mode and "Fresh up").
- Use the remote controller to make the initial settings for the ERV units.
Refer to "9. FIELD SETTING AND TEST RUN".

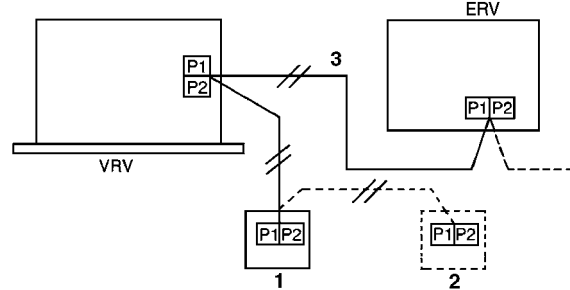

1. Main remote controller
2. Sub remote controller
3. Transmission wiring can be extended up to 1640 ft.

Pre-cool/pre-heat function

When the pre-cool/pre-heat function is set, the ERV unit will be turned on at the preset time (30, 45 or 60 minutes) after the VRV-system air conditioner begins cooling or heating operation. The function is set OFF at the factory.

Therefore, to use this function, the initial setting must be made using the remote controller.

If the air conditioner is re-started within two hours after the operation stopped, this function is disabled.

Example 1:

To switch on the pre-cool/pre-heat function and turn on the ERV unit 60 minutes after the air conditioner is turned on.

- (1) Set the mode No. to "17" for group control or "27" for individual control, the FIRST CODE NO. to "2" and the SECOND CODE NO. to "02"
- (2) Set the mode No. to "17" for group control or "27" for individual control, the FIRST CODE NO. to "3" and the SECOND CODE NO. to "03"

Example 2:

To switch the ventilation airflow to extra high setting.

(The units are set at the high airflow setting at the factory)

Set the mode No. to "17" for group control or "27" for individual control, the FIRST CODE NO. to "4" and the SECOND CODE NO. to "02"

10-2-2 Direct duct connection system for 1-group linked operation system

Transmission wiring and the setting of the switch on the PCB should be the same as for “10-2-1 Standard 1-group linked operation system”.

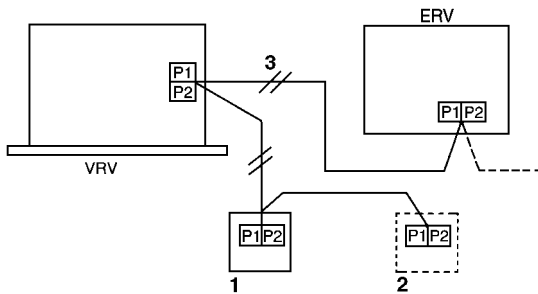

1. Main remote controller
2. Sub remote controller
3. Maximum transmission wiring length : 1640 ft.

Set the switch on the PCB to the default factory setting.

1. Be sure to set the initial settings to direct duct connection: Enabled.

Set the mode No. to “17”, the FIRST CODE NO. to “5” and the SECOND CODE NO. to “02”.

2. Settings for other ERV functions should be made using the same method as in “10-2-1 Standard 1-group linked operation system”.

10-2-3 Linked operation with more than two groups

- Mount the optional KRP4A72 Adapter PCB for remote control on the control box of ERV unit.
- A maximum of 64 air conditioners and ERV units can be connected to the F1 and F2 terminals.
- Use the remote controller to make the initial settings.

1. Remote controller
2. Transmission wiring can be extended up to 3280 ft.
3. Optional adapter PCB KRP4A72

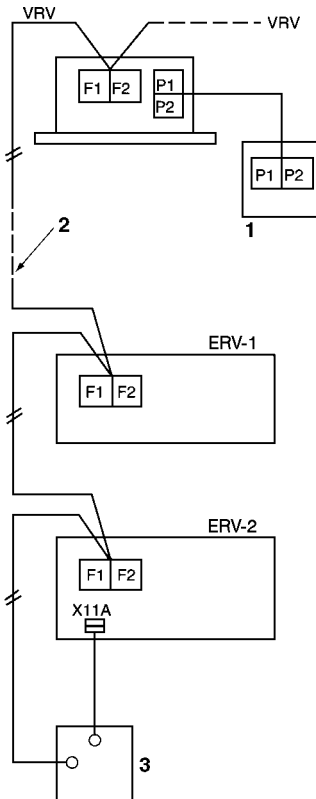

<Procedure>

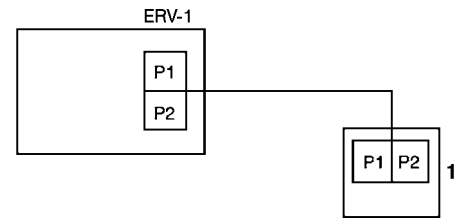

1. Remote controller

1. Turn on the power supply.
 2. Make the remote controller settings; Set the centralized zone interlock setting to ON. Mode No. “17”, FIRST CODE NO. “8” and SECOND CODE NO. “02”.
 3. Turn off the power supply.
 4. Disconnect the remote controller.
- Now the field settings are complete.

10-3 Centralized control system

10-3-1 “All” control

When using Adapter PCB for remote control (KRP4A72) or schedule timer (DST301BA61)

- A maximum of 64 air conditioners and ERV units can be connected to the F1 and F2 terminals.
- This system does not require group number setting for centralized control. (auto-address system)
- The Adapter PCB for remote control and schedule timer cannot be used together.
- The Adapter PCB for remote control can be mounted on the control box of either the ERV unit or air conditioner. (The ERV unit can accept only KRP4A72.)

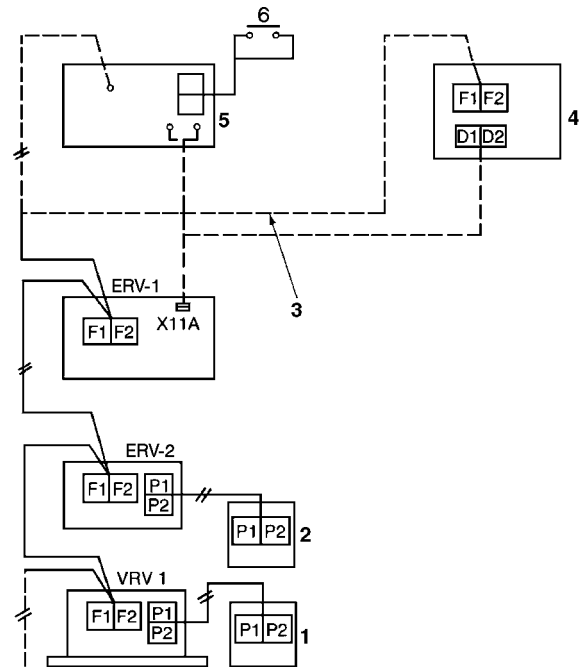

1. Remote controller
2. Remote controller
3. Transmission wiring can be extended up to 3280 ft.
4. Schedule timer (DST301BA61)
5. Adapter PCB for remote control (KRP4A72)
6. ON/OFF signal

10-3-2 “All”/“individual” control

When using the ON/OFF controller (DCS301BA61)

- A maximum of 64 air conditioners and ERV units can be connected to the F1 and F2 terminals.
- This system allows connection of four ON/OFF controllers.
- It is necessary to assign a centralized control group number to each ERV unit and air conditioner.
- Regarding the setting of the group number, refer to the section on “the centralized control group number setting” in the operation manual of the ON/OFF controller.
- Use the remote controller to make the initial settings.

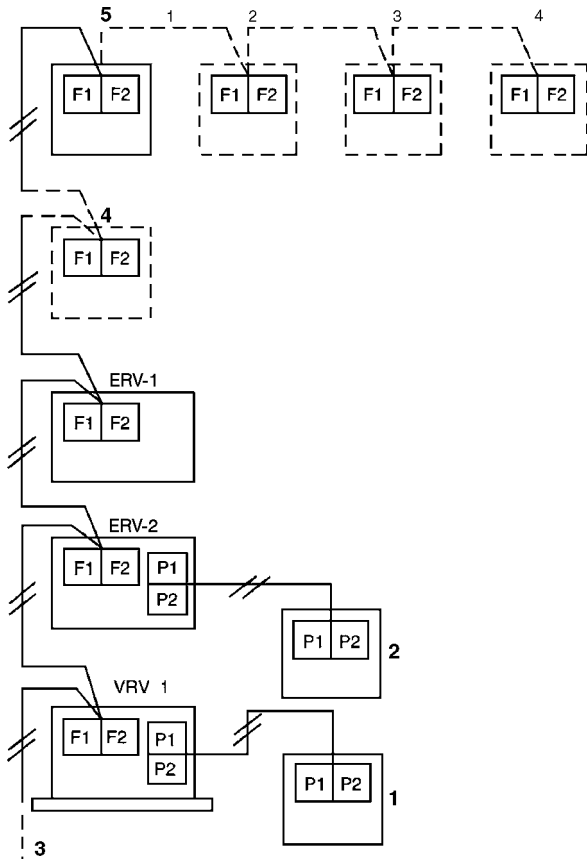

1. Remote controller
2. Remote controller
3. Transmission wiring can be extended up to 3280 ft.
4. Schedule timer
5. ON/OFF controller

Example:

Follow the procedure below to set the centralized group No. 2-05 to ERV 1.

Procedure

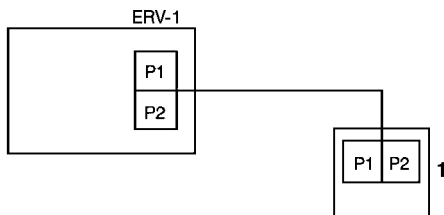

1. Remote controller

1. Turn on the ERV-1 and ON/OFF controller.
2. Set the central control group number using the field setting on the remote controller.
3. Mode No.: “00”
4. Central control group No.: “2-05”
5. Turn off the ERV-1 and ON/OFF controller.

The setting is now complete.

- For the ventilation airflow setting, follow the procedure described in the **10-3-1** section.

10-3-3 Zone control system

- A maximum of 64 air conditioners and ERV units can be connected to the F1 and F2 terminals.
- The ERV units will turn on and off in according with the zone operation command from the centralized controller.

Zone 2

The ERV units operate in the linked operation mode, as described in the section, “**10-2-3** Linked operation with more than two groups” For the initial setting, follow the procedure described in the **10-2-3** section.

- It is necessary to assign a centralized control group number to each ERV unit and air conditioner.
Regarding the setting of the group number, refer to the section on “the centralized control group number setting” in the operation manual of the Centralized controller. Refer to the “**10-3-2** “All”/individual control” section for the setting procedure.
- For the ventilation airflow setting, follow the procedure described in the **10-3-1** section.
- For the zone setting from the centralized controller, refer to the operation manual of the centralized controller.
- The centralized controller can be used to control the individual units in the zone for ventilation operation.

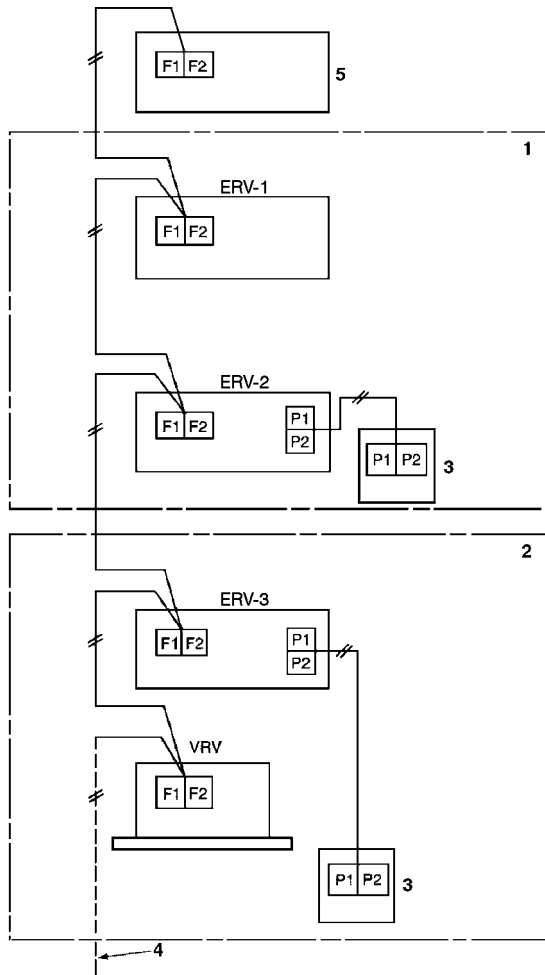

1. Zone 1
2. Zone 2
3. Remote controller
4. Transmission wiring can be extended up to 3280 ft.
5. Centralized controller (DCS302C71)

10-4 REMOTE CONTROL

10-4-1 Monitor of operation

The operation of the ERV can be monitored from the outside by the connection of the adaptor PCB for remote control KRP50-2 (option)

Be sure to connect the terminal strip on the adaptor PCB for remote control KRP50-2 (option).

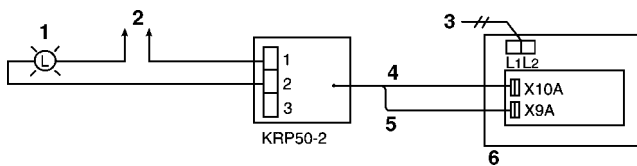

1. Operation lamp
2. Power supply
3. Power supply
4. P connector
5. 3P connector
6. PC board

Wiring adapter for remote control KRP50-2 (option) (To be placed in the control box of the ERV)

10-4-2 Fresh up operation

<Purposes>

When combined with a local ventilating fan (such as the one in bath room and kitchen), the airflow rate of ERV is balanced by either fan operation or exhaust operation.

However, a circuit with low voltage and current (24V, 10 mA) is formed between the JC and J1, so a relay with low-load contact point must be used.

<Functions>

The unit performs overcharged operation to prevent back flow of odor.

<Necessary parts>

Operation contact of exhaust ventilating fan (field supply)

<Example of control wiring>

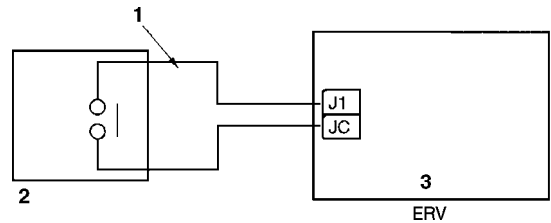

1. Transmission wiring can be extended up to 160 ft.
2. (Field supply)
3. PC board

<System description>

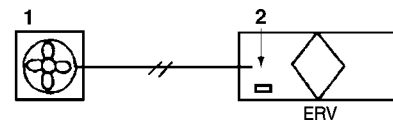

1. Local ventilating fan
2. Power supply

The field setting by the remote controller (9. FIELD SETTING AND TEST RUN)	"J1", "JC" normal open	"J1", "JC" normal close
Fresh up "OFF" (Factory setting)	Normal	Fresh up
Fresh up "ON"	Fresh up	Fresh up

10-4-3 External Damper Operation (FIELD SUPPLY)

• Explanation of functions

Intake of outdoor air can be prevented when ERV is switched OFF if this damper is incorporated in the system.

1. The PCB of the ERV unit supplies power for an external damper.

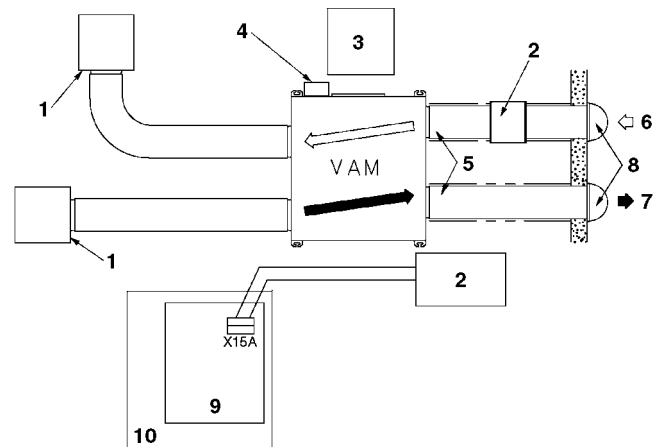

1. Air suction/discharge grille
2. External damper (field supply)
3. 18 in. Inspection hatch
4. Control box
5. Thermal insulation

- 6. OA (Outdoor air from outside)
- 7. EA (Exhaust air to outside)
- 8. Round shape hood
- 9. PC board
- 10. ERV unit

- Power supply is turned ON when the ERV unit starts operating.
Power supply is turned OFF when the ERV unit is switched OFF.

Power supply voltage	Connected load capacity
208V 230V	0.5A or less

Required setting changes for switchover to X15A output (see below for details)

• Wiring

Connect one end of the harness to X15A on the PC board and the other end to the harness leading to the damper via a connector such as a closed connector.

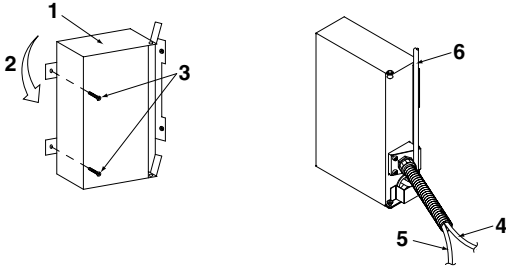

- 1. Control box cover
- 2. Open this way
- 3. Screws
- 4. To External damper
- 5. Power supply wiring
- 6. Transmission wiring

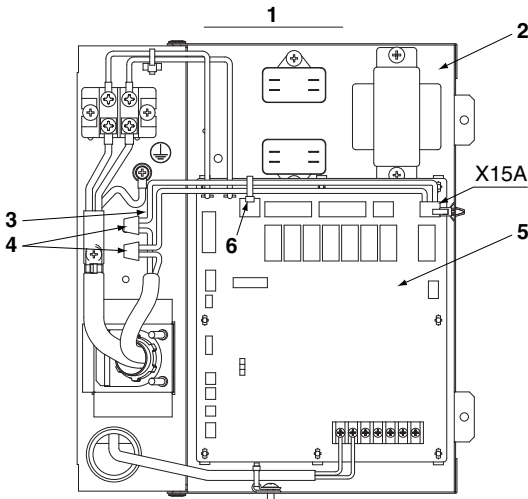

- 1. Control box Interior
- 2. Electric component mounting base
- 3. Harness (AWG20: accessory)
- 4. Closed connector (field supply)
- 5. PC board
- 6. Clamp (accessory)

With regard to a closed connector, select one that suits the wire size.

Secure the harness with the other wires by using the clamp.

• Setting changes

To make the X15A output available, change the field setting by the remote controller as below.

Mode No.: 18 (group control) or 28 (individual control)

FIRST CODE NO.: 3

SECOND CODE NO.: 03

10-4-4 Nighttime free cooling operation

<AUTOMATIC HEAT PURGE FUNCTION AT NIGHT>

The nighttime free cooling is an energy-saving function which works at night when the air conditioners are off, reducing the cooling load in the morning when the air conditioner is turned on by ventilating rooms which contain office equipment which raises the room temperature.

- Nighttime free cooling only works during cooling and when connected to VRV system.
- Nighttime free cooling is set to "off" in the factory setting; so request your dealer to turn it on if you intend to use it.

Operation image

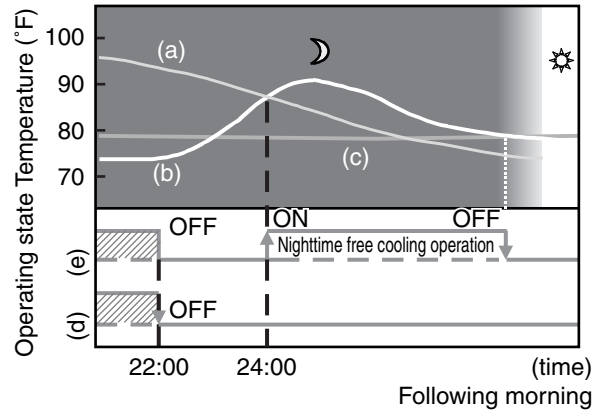

- (a) Outdoor temperature
- (b) Indoor temperature
- (c) Set temperature
- (d) Operating state of Air conditioner
- (e) Operating state of ERV

■ EXPLANATION OF NIGHTTIME FREE COOLING OPERATION IMAGE

The unit compares between the indoor and outdoor temperatures after the air conditioning operation stops for the night. If the following conditions are satisfied, the operation starts, and when the indoor temperature reaches the air conditioning setting, the operation stops.

<Conditions>

- (1) the indoor temperature is higher than the air conditioning setting and
- (2) the outdoor temperature is lower than the indoor temperature,

If the above conditions are not satisfied, reevaluation is made every 60 minutes.

— ⚠ NOTE —

- The Nighttime free cooling operation works when the ERV unit is off. Therefore, it is not possible to stop the nighttime free cooling operation, though the forced off is input from the optional controllers for centralized control.

DAIKIN AC (AMERICAS), INC.

1645 Wallace Drive, Suite 110
Carrollton, TX 75006

info@daikinac.com
www.daikinac.com

DAIKIN INDUSTRIES, LTD.

Head office:
Umeda Center Bldg., 2-4-12, Nakazaki-Nishi,
Kita-ku, Osaka, 530-8323 Japan

Tokyo office:
JR Shinagawa East Bldg., 2-18-1, Konan,
Minato-ku, Tokyo, 108-0075 Japan

